

深圳市运天戈科技有限公司

ShenZhenShi YunTianGe S&T CO .,LTD

PRODUCT SPECIFICATION

Customer (客户名称) : _____

Customer No.(客户编号) : _____

Product No. (产品编号): YTG-P10019-C1F1

深圳市运天戈科技有限公司

ShenZhenShi YunTianGe S&TCO .,LTD

PREPARED (制作)	CHECKED (审核)	APPROVED (批准)

Customer Approval 客户批准	<input type="checkbox"/> Accept 接收 <input type="checkbox"/> Reject 拒绝 Comment 意见: Approved by (确认人)
---------------------------	---

ShenZhenShi YunTianGe S&T CO .,LTD

Tel: 138 23768287

Phone : +86 0755 81499055

Fax : +86 0755 81499010

Email : wangxian8838@126.com

地址: 深圳市宝安区沙井镇和一鸿江工业园2栋5楼

深圳市运天戈科技有限公司

ShenZhenShi YunTianGe S&T CO .,LTD

NOTICE:

The content of this specification is subject to change without further notice. YTG assumes no responsibility concerning the accuracy, adequacy, or completeness of this specification. YTG makes no commitment to update, or to keep current the information and material contained in this specification.

Such information and material may change to conform to each confirmed order. In no event shall YTG be made responsible for any claims attributed to errors, omissions, or other inaccuracies in the information or material contained in this specification. YTG shall not be liable for direct, indirect, special incidental, or consequential damages arising from the use of such information or material.

The software (if any) described in this specification is furnished under a license or nondisclosure agreement, and may be used or copied only in accordance with the terms of such agreement.

YTG products are not intended for use in life support appliances, devices, or systems. Use of YTG product in such applications is not supported and is prohibited.

NO PART OF THIS SPECIFICATION MAY BE REPRODUCED OR TRANSMITTED IN ANY FORM OR BY ANY MEANS WITHOUT THE EXPRESSED WRITTEN PERMISSION OF YTG.

深圳市运天戈科技有限公司

ShenZhenShi YunTianGe S&T CO.,LTD

Contents 目录

1. General Specification 产品规格
2. Electrical Characteristics 电气参数
3. Optical Characteristics 光学参数
4. Reliability 信赖性
5. Durability 寿命
6. Touch panel description 触摸屏功能描述
 - 6.1 touch panel drawing 外形图
 - 6.2 Block diagram 功能结构图
 - 6.3 Touch panel pin assignment 引脚定义
7. Appearance Inspection 外观检验
 - 7.1 Inspection Conditions 检验条件
 - 7.2 Criteria 判定标准
8. Precautions 注意事项
9. Packing Drawing 包装说明

Appendix 附件

工程图

深圳市运天戈科技有限公司

ShenZhenShi YunTianGe S&T CO.,LTD

1. General Specification 产品规格

Item 项目	CONTENTS 内容	Unit 单位
Outline Dimension 外形尺寸	以确认工程图为准	mm
Active Area(W*L)动作区	224.12*126.78	mm
View Area 可视区	223.12*125.78	mm
TP size (inch) 英寸尺寸	10.1	inch
Interface Type 接口种类		-
IC Type IC 型号		-
Number of touchpoint 触点数量	10	-
Operation Temperature 工作温度	TOPL = -10, TOPH =60	°C
Storage Temperature 储存温度	TSTL = -40, TSTH =85	°C
Sensor thickness ITO 厚度	1.1	mm
Coverlens thickness 盖板厚度	0.25	mm
Lens Color 盖板颜色	黑色	-
Input force 输入外力	<10	g
Surface hardness 表面硬度	>3	H

深圳市运天戈科技有限公司

ShenZhenShi YunTianGe S&T CO.,LTD

2. Electrical Characteristics (Ta=25°C) 电气参数

Item 项目	Symbol 标识	Condition 条件	Min.最小值	Type典型值	Max.最大值	Unit 单位
Power Supply 电压	VCC	--				V
Supply Current 电流	IDD	Vcc =3.3V Free mode	--	--	--	mA
		Vcc =3.3V watch mode	-	-	--	mA
		Vcc =3.3V Active mode	-	-	--	mA
		Vcc =3.3V Fast mode	-	<30	-	mA

3. Optical Characteristics 光学参数

Item 项目	CONTENTS 内容	Remark 备注
Transparency 透过率	>86%	

4. Reliability 信赖性

Item 项目	Specifications 规格	Remark 备注
High Temperature Storage 高温存储	70°C,240hrs, Normalized for 2 hrs	
Low Temperature Storage 低温存储	-20°C,240hrs, Normalized for 2 hrs	Non-condensing无结露
Temperature/ Humidity Storage 储存温度/湿度	60°C/90% RH,240hrs, normalized for 2 hrs	Non-condensing无结露
High Temperature Operation 高温工作	55°C,24hrs, Perform well	
Low Temperature Operation 低温工作	-10 °C,24hrs, Perform well	Non-condensing无结露
Temperature/ Humidity Storage 储存温度/湿度	60°C/90%RH,24hrs, Normalized for 2 hrs	Non-condensing无结露
Thermal Shock 冷热冲击	-20 ~ 70°C, 60 Mins/cycle , Total 10 Cycles, Normalized for 2 hrs	

深圳市运天戈科技有限公司

ShenZhenShi YunTianGe S&T CO .,LTD

5. Durability 寿命

Item	Specification	Condition
Hitting life 撞击寿命	35,000,000 times	Hitting test may cause surface slight scratch yet the function stays intact 功能OK,外观轻微刮伤判OK
Panel Slide Test 滑动测试	250g, 20mm, 100,000 times	Slide test may cause surface slight scratch yet the function stays intact功能OK,外观轻微刮伤判OK.

6. Touch panel description 触摸屏功能描述

6.1 touch panel drawing 外形图

See appendix(见附工程图)

6.2 Block diagram 功能方框图

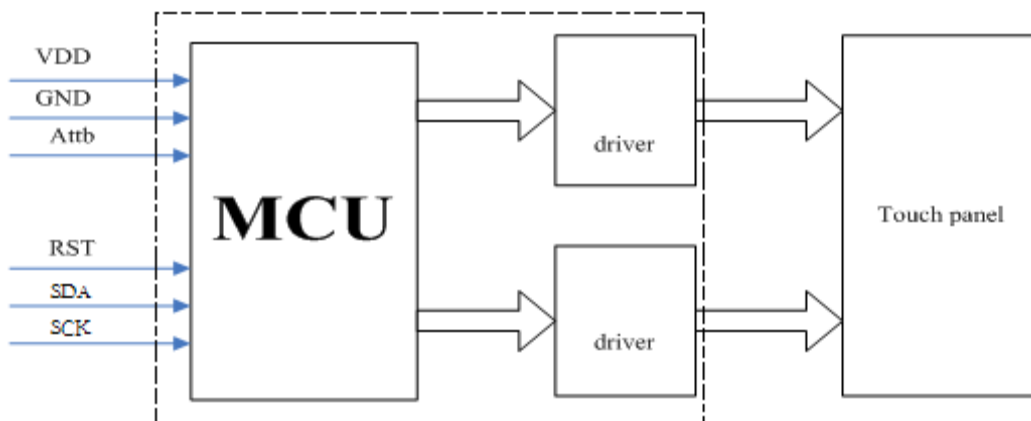

深圳市运天戈科技有限公司

ShenZhenShi YunTianGe S&T CO.,LTD

6.3 Touch panel pin assignment 引脚定义

Pin	Symbol	PIN	Symbol	PIN	Symbol	PIN	Symbol	PIN
1	GND	13	RX12	25	TX4	37	TX16	49
2	RX1	14	RX13	26	TX5	38	TX17	50
3	RX2	15	RX14	27	TX6	39	TX18	
4	RX3	16	RX15	28	TX7	40	TX19	
5	RX4	17	RX16	29	TX8	41	TX20	
6	RX5	18	GND	30	TX9	42	TX21	
7	RX6	19	GND	31	TX10	43	TX22	
8	RX7	20	GND	32	TX11	44	TX23	
9	RX8	21	GND	33	TX12	45	TX24	
10	RX9	22	TX1	34	TX13	46	TX25	
11	RX10	23	TX2	35	TX14	47	TX26	
12	RX11	24	TX3	36	TX15	48	TX27	

7. Appearance Inspection 外观检验

7.1 Inspection Conditions 检验条件

1. Environment: $22 \pm 3^{\circ}\text{C}$, Inspection distance: $30 \pm 10\text{cm}$.

2. Angle of Vision: $30^{\circ} \sim 90^{\circ}$

3. Lighting illumination: 17W fluorescent luminant lamp is used for appearance inspection.

Detail of settings is shown in figure 13.1 & 13.2 .

4. Minor impurities outside viewing area are acceptable unless their existence affect electrical functions.

深圳市运天戈科技有限公司

ShenZhenShi YunTianGe S&T CO.,LTD

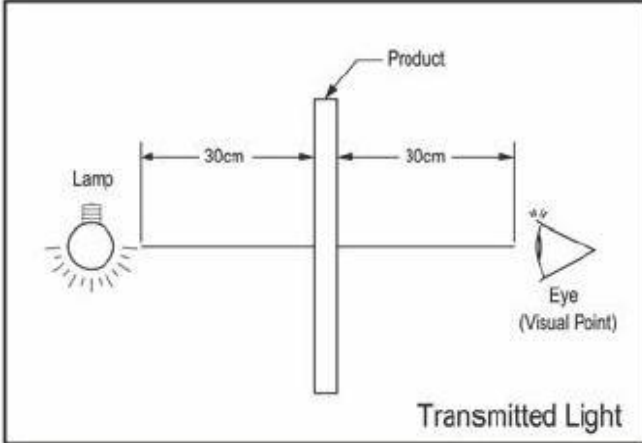

figure 13.1

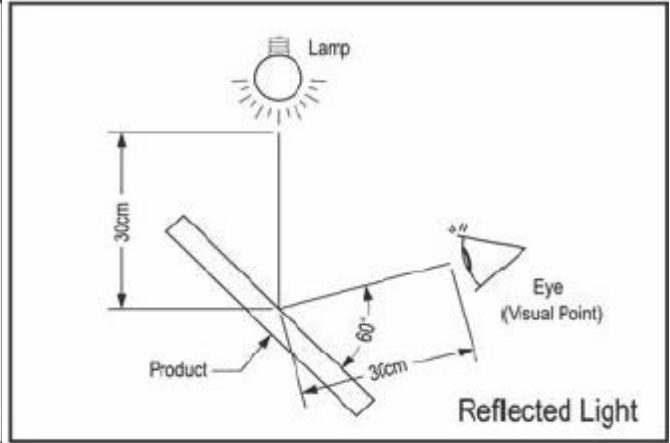

figure 13.2

7.2 Criteria 判定标准

Item 项目	Specification 规格
Particle 灰尘	(1) $D \leq 0.2$ OK (2) $0.2 < D \leq 0.35$ (each area contains ≤ 3 , total ≤ 5) OK (3) $D > 0.4$ NG
Linear Object 线状异物	(1) $W \leq 0.05$ OK (2) $0.05 < W \leq 0.1$ and $L \leq 5.0$, total ≤ 3 OK (3) $W > 0.1$ NG Remark: the particle will be ignored when it is removable by cleaning
Scratch 刮伤	(1) $W \leq 0.025$ OK (2) $0.025 < W \leq 0.05$ and $L \leq 12.0$, total ≤ 5 OK (3) $0.05 < W \leq 0.1$ and $L \leq 6$, total ≤ 5 OK (4) $W > 0.1$ NG
Remark 备注	1. D=Diameter 2. W=Width 3. L=Length

深圳市运天戈科技有限公司

ShenZhenShi YunTianGe S&T CO.,LTD

8. Precautions 注意事项

Storage	Store panel under the temperature and humidity range pre-specified. Direct sunlight exposure or piling should be avoided.
Unpack拆包	Unpack the box with the printed red arrow pointing up.
Handling 使用中	(1) Use clean sacks or glove to prevent fingerprints and/or stains left on the panel. Extra attention and carefulness should be taken while handling the glass edge. (2) Avoid high voltage and/or static charge (3) Holding the panel instead of the tail at all time.
Cleaning 清洁	(1) Use neutral detergent or isopropyl alcohol on a clean soft cloth to clean the panel surface (2) Prevent using any kind of chemical solvent, acidic or alkali solution.
installing 安装	(1) Excessive force or strain to the panel or tail is prohibited. (2) Retain at least 0.3 mm clearance between panel and display module. (3) Gasket or cushion pads around the edge of the panel may segregate waterand/or dust contamination.
Operating 操作	(1) Touch the panel with your finger or stylus only to assure normaloperation. Any sharp edged or hard objects are prohibited. (2) Operate the panel in a steady environment. Abrupt variation on temperature and humidity may cause malfunction of the panel.
Others 其他	(1) Keep the panel surface clean. Prevent any kind of adhesive applied on the surface. (2) Avoid high voltage and/or static charge.

--	--

深圳市运天戈科技有限公司

ShenZhenShi YunTianGe S&T CO.,LTD

9. Packing Drawing 包装说明

Packing Material 包装材料	Size 尺寸	Weight 重量
Carton 纸箱	400*315*290mm	TBD
Plastic Bag 气泡袋	290*275*5mm	TBD

包装参考图

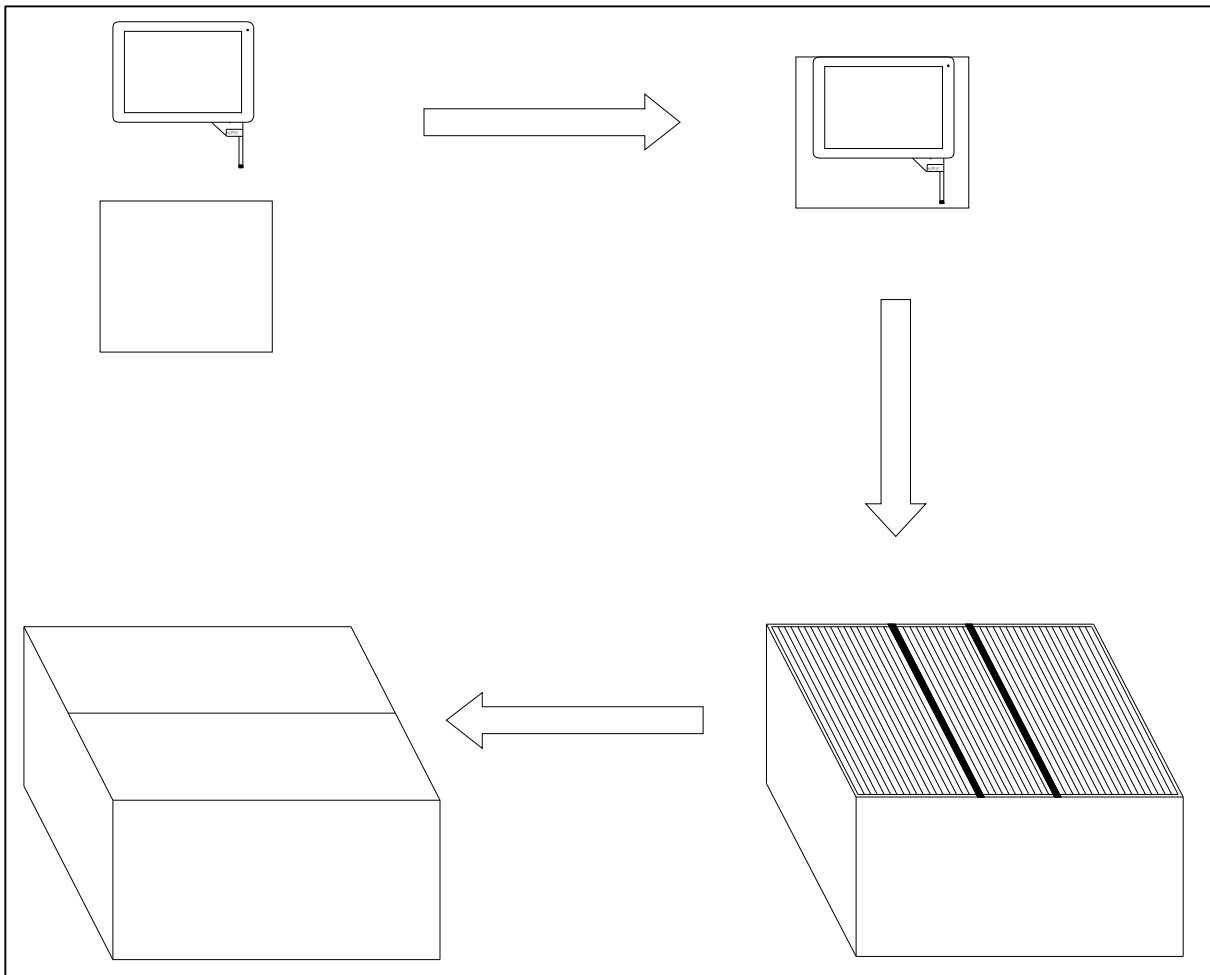

说明：每箱中有两个隔板，每箱装50片

Appendix 附件

REV.	DATE	CHANGE DESCRIPTION
1.0	2023/7/20	First Issue

正面视图

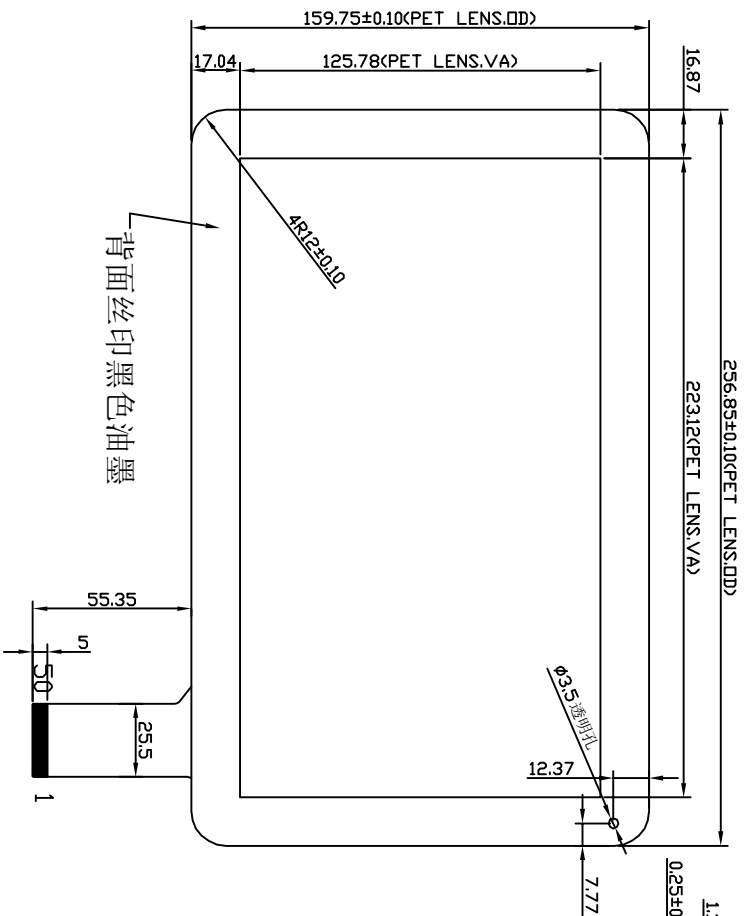

侧面视图



背面视图

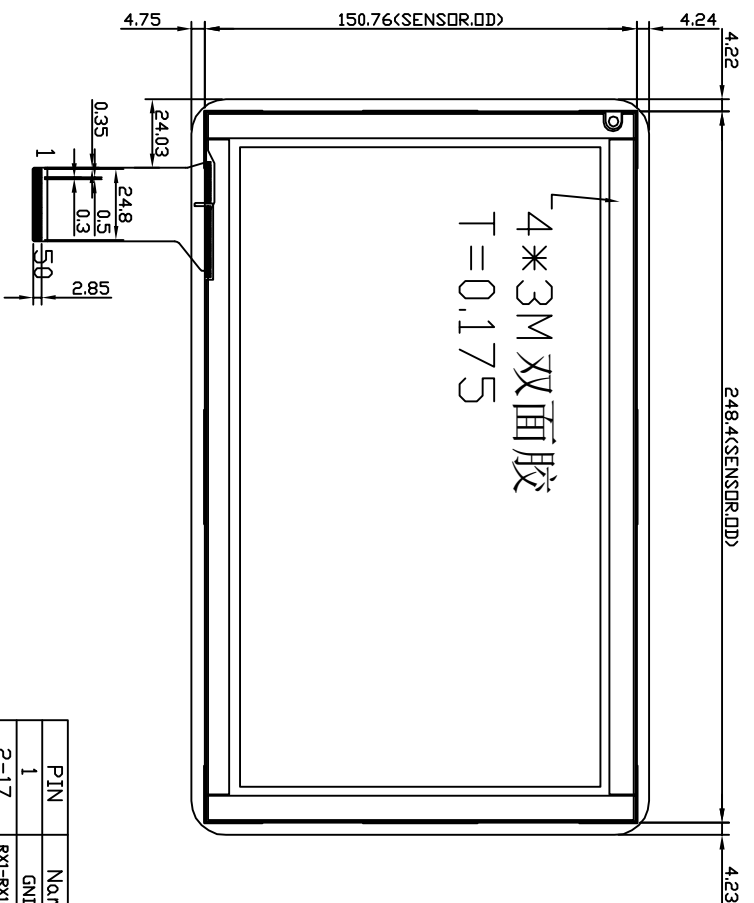

PIN	Name
1	GND
2-17	rx1-rx16
18-21	GND
22-49	TX1-TX8
50	GND

由 Autodesk 教育版产品制作

由 Autodesk 教育版产品制作

备注:

- COVER LENS的表面硬度>3H,底色油墨区域没透光现象。
- 油墨厚度8~12um,油墨硬度≧4H
- LENS通过钢球冲击实验: 64克钢球,高度65CM作钢球冲击实验,无破碎。
- 产品物料满足ROHS和无卤素要求。
- 无油墨处透光率≧90%。
- CS ≧ 450MPA, DOL ≧ 8um。
- 储存温度: -40℃ to 85℃。

请客户确认图纸!

确认签名:

DRAW No:	YTG-P10019-C1F1	深圳市途天戈科技有限公司	
DRAWING BY	YZG Aug20/2013	Shenzhen Yun Tong Technology Co.	
CHECKED BY	LSL Aug20/2013	Sheet: 1/1	SCALE: 1:1
APPROVED BY		Unspecified Tolerance: ±0.2	REV: V1.0